

# Creating Science – Smushy Circuits

---

*How does electricity work? #CreatingScienceSmushyCircuits*

## Suggested outcomes

(NOTE: This is by no means an exhaustive list of possible outcomes, neither is it intended that ONLY these outcomes can or should be met. Science is a deeply interrelated activity, and you may find cross curriculum links you can and should use.)

### Science Understanding:

- Physical sciences y6: Electrical energy can be transferred and transformed in electrical circuits and can be generated from a range of sources ([ACSSU097](#))
- Physical sciences y3: Heat can be produced in many ways and can move from one object to another (ACSSU049)

### Cross curricular outcomes

Visual arts: Years 5 and 6 Content:

- Develop and apply techniques and processes when making their artworks (ACAVAM115)
- Plan the display of artworks to enhance their meaning for an audience (ACAVAM116)

Technology: Years 5 and 6 Content Descriptions.

- Design and Technologies Knowledge and Understanding : Investigate how electrical energy can control movement, sound or light in a designed product or system (ACTDEK020)
- Design and Technologies Processes and Production Skills: Select appropriate materials, components, tools, equipment and techniques and apply safe procedures to make designed solutions (ACTDEP026)

### Science vocabulary words

Tier 1 (Everyday words) Heat, electricity, battery, playdough.

Tier 3 (Specialised vocabulary)

- Circuit: Something that goes in a circle. Electricity must run in a circle back to the battery if it is going to work.
- LED. Short for Light Emitting Diode. A special light that glows quite brightly without wasting too much energy as heat. However, if you put the electricity on the wrong way it can BREAK.

## Warning

- WIRES THAT CARRY ELECTRICITY GET HOT!!!!
  - So please be careful. Remind children to watch fingers. The voltage used here should not be enough to scald fingers, but have a wet cloth on hand anyway. Also, if children cause a short circuit and leave it for a while it can get extremely hot, hot enough to start a fire. Please beware.
- Playdough LOOKS edible; and it is. But please discourage kids from eating it even though we know someone will try to. The salt alone *usually* discourages them.
- Make sure only those with sufficient responsibility cook the smushy circuit dough. It can be quite dangerous to use a stove, please manage appropriately.
- Store in a cool, dry place. Make sure you **throw out** your completely biodegradable smushy circuits after about a week.

## Preparation

To make the conductive dough, you will need:

- Grown up help - some cooking is required
- A cup of plain flour
- A cup of warm water
- 1/4 cup of salt
- 3 Tbsp Cream of Tartar
- 1 Tbsp oil
- Food colouring - this is optional and added mess!

To complete your smushy circuit you will need:

- A 9v battery and leads
- A LED light or two
- Smushy circuit dough, from above
- A clean place to work

## Learning Intent (student friendly)

'We are learning to' (WALT). Complete a working electronic circuit.

### Success criteria

'What I'm looking for' (WILF). The LED to light up, and the students to explain how it works.

### Student learning goals

Help students make a self-monitored learning goal for this lesson.

## Evidence of learning

How will you know when the learning goal is achieved? What EVIDENCE do you have that your students have met or exceeded the learning expectations?

- The LED will light up.
- A completed circuit diagram of the flow of electricity.

## Suggestions for other year levels

As always, more material is presented here than can be used by the average class during the average lesson time. However, since the students questions can and should guide student learning, more material is presented for you convenience. Remember, it is not uncommon for students to only remember those points which answered their personal questions.

### Younger:

This activity is well suited to this age group, but they will need help. Also, wires left running will get HOT. Children at this age can have difficulty with focus. Avoid tangents into interesting side tracts if you're attempting to make a key point.

### Middle:

This activity is well suited to this age group. Challenge students to get two LEDs to light up at once, in series and in parallel circuits.

### Teen:

Challenge students to calculate the exact resistance of the dough. How much energy is lost per centimetre of dough?

## Engage

- ⇒ Note the Learning Intention of this lesson for students.
- ⇒ Make sure all students write down any questions they may have generated during this phase regarding the topic for today.

Show students the LED and battery. Ask how they think the electricity runs through the light to make it work.

## Explore

- ⇒ Encourage and validate student explanations of this phenomenon. You may like to ask students to write or draw their explanation personally to avoid embarrassment to students unfamiliar with this material. Remember, 'I don't know' is a valid explanation in science – it is the beginning of learning new things!

Give students the LED and the battery. Challenge them to light up the light. They should figure out fairly quickly that they need a kind of circle to and from the battery to light up the light.

## Explain

We usually explain that electricity, to work, must flow in a circle – from the place it starts and back once again.

If it's going the wrong way, the LED will not light up.

Electricity comes out of the -ve terminal of the battery, through the black wire, into the LED and lights it up, then along the red wire and back into the battery.

## Elaborate

- ⇒ Ask students if they can design new ways to test this explanation, is it really sufficient? Can they think of further or better explanations, and the experiments needed to test them?

Try building the smushy circuits:

- ? Can you get the LED to light up with the smushy goo in the circuit?
- ? Why is the light dimmer now?
- ? What happens if you move the two terminals (the black and red) closer to each other?
- ? What cool shapes can you make out of the smushy circuit?
- ? Can you get two LEDs to light up?

## Evaluate

- ⇒ Review with students what they felt they learnt from this lesson. Did they have any questions at the start that they feel were answered?
- ⇒ What worked best to make the LED light up?
- ⇒ Do you feel you know what the invisible electricity is doing in the wires? Which way is it flowing?

## Success criteria

- ⇒ Review the Learning Intentions of this lesson with students. Was it met?

At the end of each class, review the learning objective and see how we did. Ask:

- Did you achieve your learning goal?
- What worked to help you achieve it?
- What might you do better next time?
- (If needed) where can you go for extra help or information?

# Assessment

## Prior Learning:

Pretest - how does electricity flow in a light bulb or LED?

Be sure to watch out for the following common alternative conceptions:

- MOST students think electricity is made in the battery and consumed in the components such as a lightbulb. This is an alternative conception not very helpful at understanding how circuits work. Often the analogy of a waterfall is used: The water is not used up as it flows along objects in its path, but it can be slowed down by things such as waterwheels or hydroelectric power plants.

## Formative:

As students are learning, help them self-monitor their own learning and achievements.

- Does it matter which terminal of the battery is touching the different feet of the LED?
- What happens if there's a tiny break in your circuit?
- Can you feel the wires getting HOT?

## Summative:

Help students consider ways they can communicate their new understanding to others, just as scientists need to do.

Tell or narrate a story of the adventures of an electron as it flows from the battery, through the circuit, and back in again. While he's not used up, his energy sure is!

Draw a functional diagram of the flow of electricity in a light.

## So what?

Electricity must flow in a circuit to work.

- Devices around the home use the planet earth as one conductor to get the electricity flowing away. When you touch a live electric device around the home, such as sticking a knife in a toaster, it can flow through you as your body completes the circuit with the ground - very dangerous!!!

## Creating science

### Science Understanding:

As we learnt how electricity flows through circuits, we saw that:

- Physical sciences y6: Electrical energy can be transferred and transformed in electrical circuits and can be generated from a range of sources ([ACSSU097](#))

As we avoided burning our fingers, or otherwise, we discovered that:

- Physical sciences y3: Heat can be produced in many ways and can move from one object to another (ACSSU049)

## Science inquiry skills

Using unique materials, we were able to light and LED as we:

- Planning and conducting 3: With guidance, plan and conduct scientific investigations to find answers to questions, considering the safe use of appropriate materials and equipment (AC SIS065)

## Science as a human endeavour

As we avoided burning or electrocuting ourselves, we see that:

- Use and influence of science 3: Science knowledge helps people to understand the effect of their actions (ACSHE051)

## Appendix

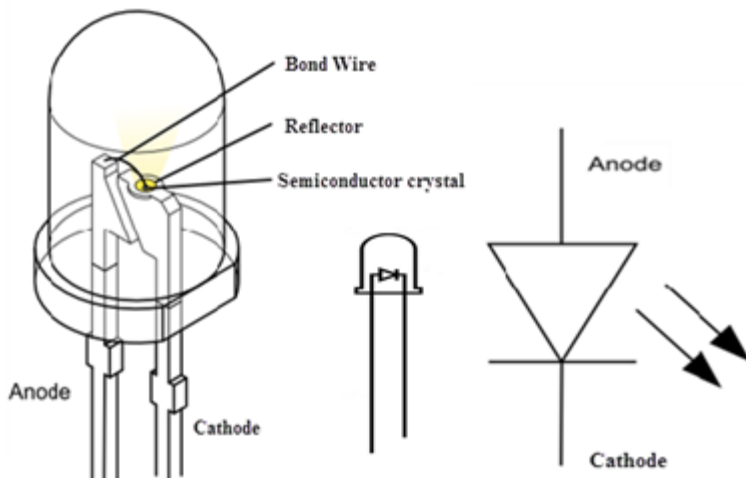

Taken 27 jul 18 from <https://www.elprocus.com/wp-content/uploads/2017/07/Structure-of-an-LED-and-circuit-symbol.png>

The circuit diagram for the Smushy Circuit:

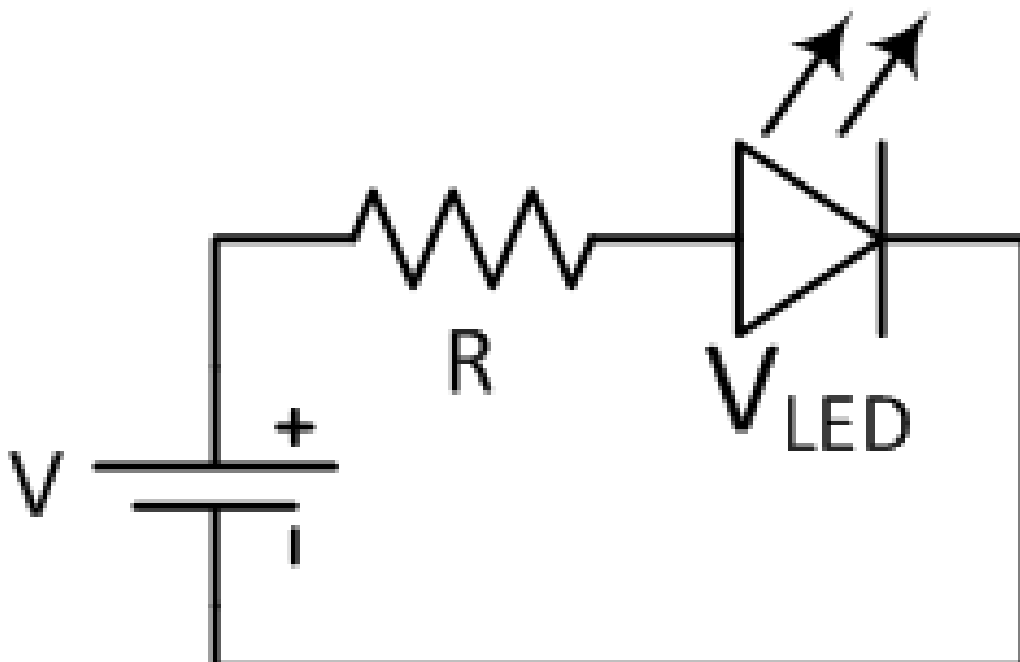

Where

$V$  = voltage, in our case, 9 of them.

$V_{LED}$  = the little light

$R$  = Resistance, in our case, the smushy dough

Taken 27 jul 18 from <http://www.resistorguide.com/pictures/resistors-in-LED-circuits.png>

## Tips from the Masters to make it work:

1. Wires get hot – pressing them on is a great way to make sure you know how hot they're getting. If you want to leave them on for a bit, try bending them both and latching them on to each other, but watch out for even more heat in this case! We tried to develop a system that is as safe as can be, but we cannot guarantee all materials are without fault!
2. The black wire goes to the short end of the LED.

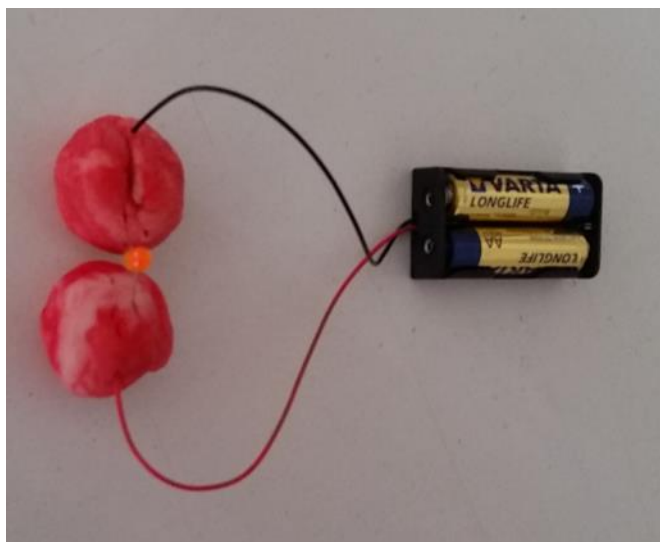

## With a circuit – light on

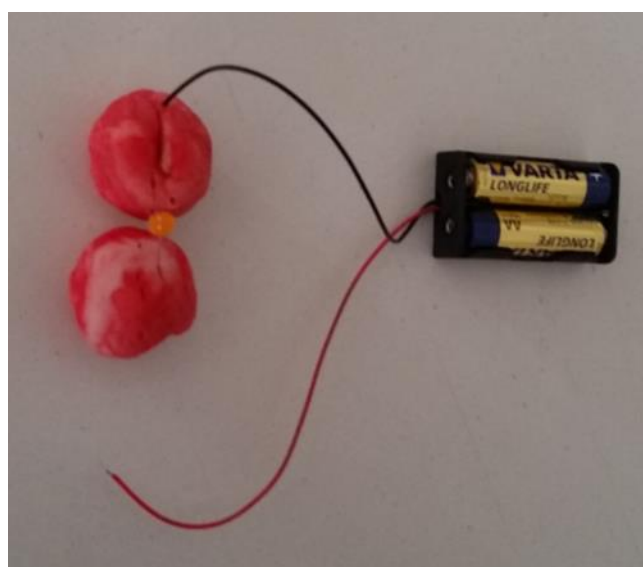

## Without a circuit – light off



## We start like this



## And get like this





**Easy for everyone!**



**LEDs in parallel – two lights light it up!**

(Battery runs out twice as fast)